

**Anschlußbild**

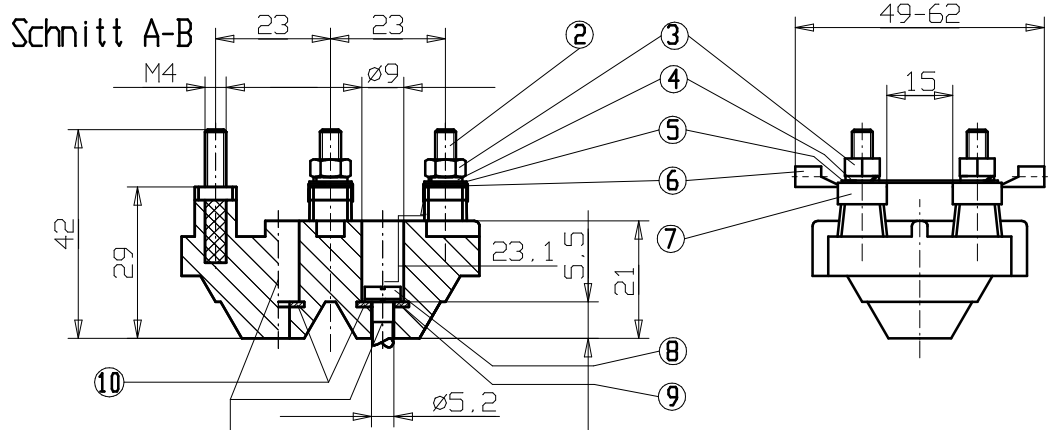

Befestigung mit 2 Schrauben

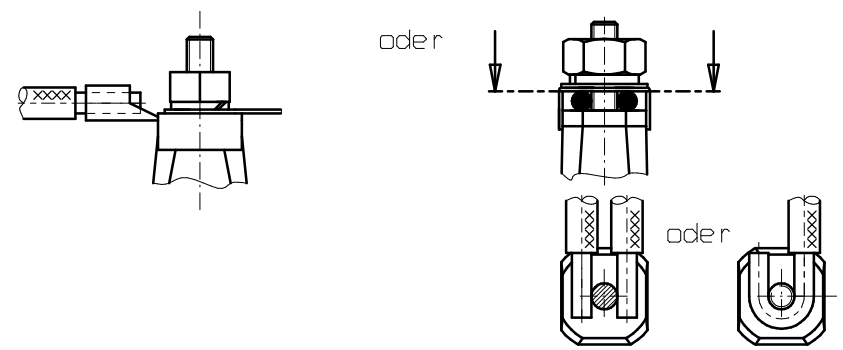
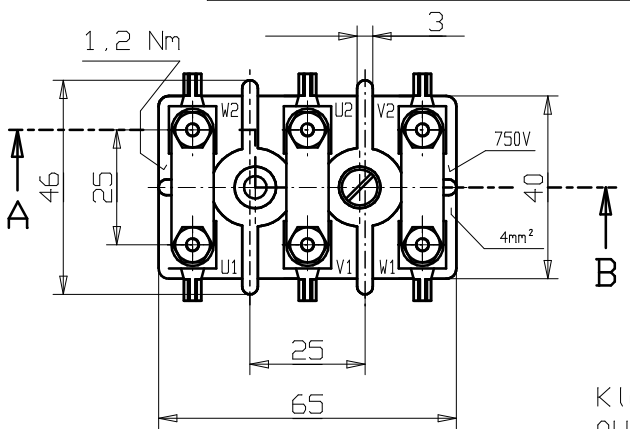

Klemmenbezeichnung (U1.V1...) auswechselbar Wegfall einzelner Bolzen

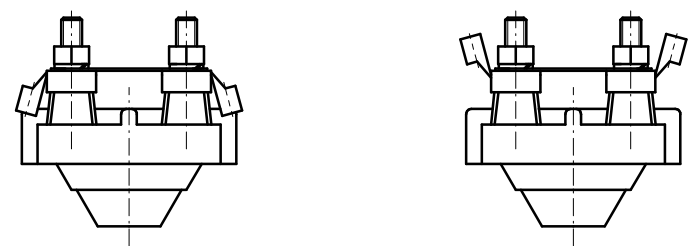

Ing. Erich Geiss GmbH & Co.KG  
Elektrotechn. Fabrik

D-Sulzbach/Ts. , den 15.01.99

Kunde			Maßstab		
			Werkstoff		
			Datum	Name	Benennung
			Gez. 14.12.98	A. Müller	<b>KB 5590Ex-5,2</b>
			Gepr		
			Norm		
			Ing. Erich Geiss GmbH & Co.KG Elektrotechn. Fabrik Tel 06196-75137 Fax 06196-75140		Zeichnungsnummer
					98.161.00
ZustÄnderung	Datum	Name	Ersatz f.		Ersetzt d.

Blatt  
Bl.